



RP32H-WIFI

Wi-Fi Thermostat w/Humidity Control

**Standard (Gas/Electric) up to 2H/2C
Heat Pump up to 3H/2C**

7 Day Programmable ~ 4 Events/Day

Integrated Web Server

**Secure Direct Connection via any Wi-Fi
Network and the Internet**

GENERAL DESCRIPTION:

The RP32H-WIFI is a Wi-Fi networkable thermostat with an advanced remote sensor bus, designed for new or replacement commercial or residential applications. With integrated logic for both conventional and heat pump applications, the thermostat controls up to three (3) stages of heating and two (2) stages of cooling, as well as *humidification* and *dehumidification* control. Using your favorite browser, Net/X™ makes it simple with near effortless setup of your daily schedules and vacations. The powerful integrated web server allows scheduling of up to 4 events per day, and the unique scheduling structure also supports the powerful features of adjustable temporary override times and temperature ranges, occupied and unoccupied events, keypad lockout and many more features. Each stand-alone thermostat includes integrated local weather & forecasts, email & text message alerting for both customer and service personnel.

If remote sensing is needed, use the UP32H-WIFI Wi-Fi thermostat.

DirectConnect™ & CloudConnect™ Included

STANDARD FEATURES:

- Integrated Web Server for Connectivity from Any Modern Web Browser
- Integrated Humidity Sensor & Relay for Humidification and Dehumidification Control
- Alternately Use Humidity Relay for Fresh-Air Damper Control or an Auxiliary Controlled General Purpose Relay
- Automatic Recognition of Browser Resolution and Formatting for Specific Screen Sizes
- Email & Text Message Alerting for up to 4 Recipients; Alerts include Hi/Lo Temps for Indoor, Outdoor, Supply, Return, and Aux Temps, Inefficient Equipment Runs, Change Filter Notifications, Two Digital Inputs (think Condensate & Fault)
- Integrated Net/X™ API, Allowing for Development of 3rd Party Apps
- Selectable Fahrenheit or Celsius Display
- Automatic Changeover from Heat-to-Cool and Cool-to-Heat
- Fan Selector for Automatic or Continuous Fan Operation; Programmable Recirculation Fan
- Vacation Button for Extended Override with Selectable Length, Start and Return Time
- Resume Button for Cancelling Temporary and Vacation Functions
- Commercial Lockout with Programmable Temporary Override Time and Temp Adjustment
- 3 LED lights; 1 for E-Heat indication and 2 for status indication
- Up to 4 independent schedules per day, programmable via communications
- Adaptive Recovery for Schedules allows system to achieve desired setpoint at the beginning of the schedule
- Efficient Equipment Restart™ randomizes equipment starts to minimize multiple units turning on simultaneously when there are multiple UP32 and/or RP32 thermostats at the location
- Random Restart on power up randomly staggers restart of HVAC system after a power outage to minimize peak in-rush current for a facility
- Integrated Weather Current Conditions and 7-Day Forecasts



SPECIFICATIONS:

Rated Voltage:	20V to 30VAC, 24VAC nominal
Rated A.C. / D.C. Current:	0.05 to 0.75 AC / 0.0 to 0.75 DC Amp continuous, per output, surges to 3 Amps max.
Temperature Control Range:	Heating: 38 to 88°F (6 to 30°C) in 1° steps Cooling: 60 to 108°F (16 to 40°C) in 1° steps
Thermostat Sensing Range:	20 to 124°F (0 to 48°C) Control Accuracy: +/-1°F @ 68°F (0.5°C @ 20°C)
Minimum Deadband:	2°F (1°C)
Humidity Control Range:	Humidify: 10% to 60%RH in 5%RH steps Dehumidify: 35% to 75%RH in 5%RH steps
Wireless:	802.11 b/g radio. FCC certified.
Dimensions:	4.5"H x 4"W x 1"D (114mm x 102mm x 26mm)
Thermostat LEDs:	Red – Emergency Heat, Yellow – Inefficient Equipment Run, Green – Change Filter
Equipment Terminations:	R - 24V switching voltage, W1 - Heat1 or Aux/Emer Heat, G - Fan, Y1-Compressor1, Y2 - Compressor2, O/W2 - Heat2 or Rev. Valve in Cooling, B - Rev. Valve in Heating, K/H/D – Relay / Humidify / Dehumidify
Power Terminations:	24V - remote power (not used), 24V(c) - power common (from HVAC equipment)

WIRING DIAGRAMS:

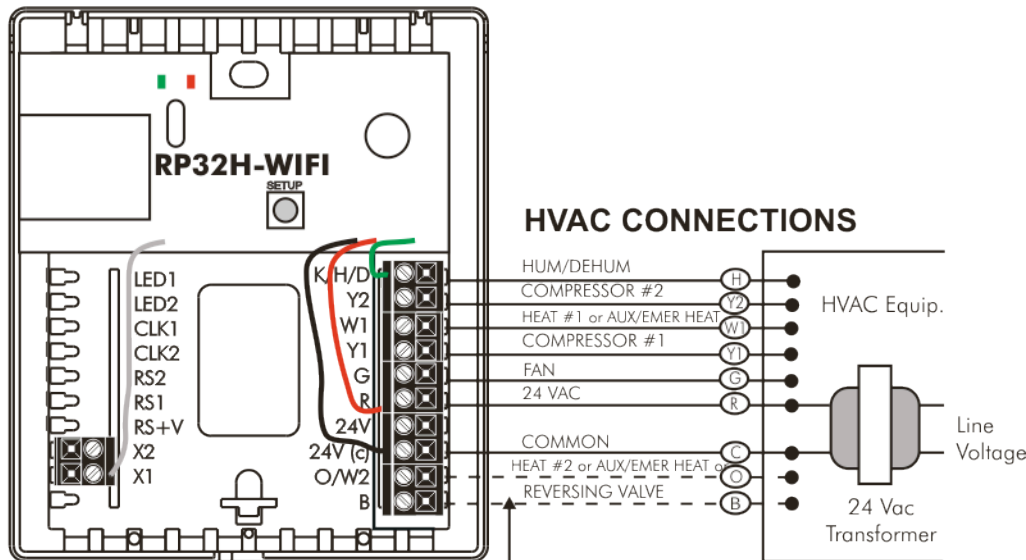

Note: Check Heat Pump Installation Instructions for reversing valve connection, either 'O' or 'B'.

OUTPUT TERMINAL FUNCTIONS

- K/H/D** Humidification or Dehumidification or Aux. Relay
- Y2** Energizes compressor for second stage cooling, or for heat pumps, either second stage heating or cooling
- W1** Energizes heater for first stage heating, or for heat pumps, aux/emmer heat
- Y1** Energizes compressor for first stage cooling, or for heat pumps, either first stage heating or cooling
- G** Energizes fan circuit with a call for heating or cooling
- R** Independent Switching Voltage from HVAC equip
- 24V** 24Vac
- 24V(c)** 24Vac Common
- O/W2** Energizes heater for second stage heating, or for heat pumps, energizes the reversing valve in cooling mode
- B** Energizes the reversing valve in heating mode

THERMOSTAT DIP SWITCH SELECTIONS

(FACTORY DEFAULT) OFF	ON
GAS / ELECTRIC	<input type="checkbox"/> 1 HEAT PUMP
ADAPTIVE RECOVERY ON	<input type="checkbox"/> 2 ADAPTIVE RECOVERY OFF
4 MINUTES (ON/OFF)	<input type="checkbox"/> 3 2 MINUTES (ON/OFF)
UNLOCKED	<input type="checkbox"/> 4 LOCKED
DIP1=OFF : ELECTRIC	<input type="checkbox"/> 5 DIP1=OFF : GAS HEAT
DIP1=ON : HP NORM	<input type="checkbox"/> 6 DIP1=ON : HP DUAL FUEL
1-STAGE CONTROL	<input type="checkbox"/> 7 2-STAGE CONTROL
+/- 3F OVERRIDE RANGE	<input type="checkbox"/> 8 +/- 5F OVERRIDE RANGE
NOT USED (OFF)	<input type="checkbox"/> NOT USED (KEEP OFF)